

SQB Loadcell 3T

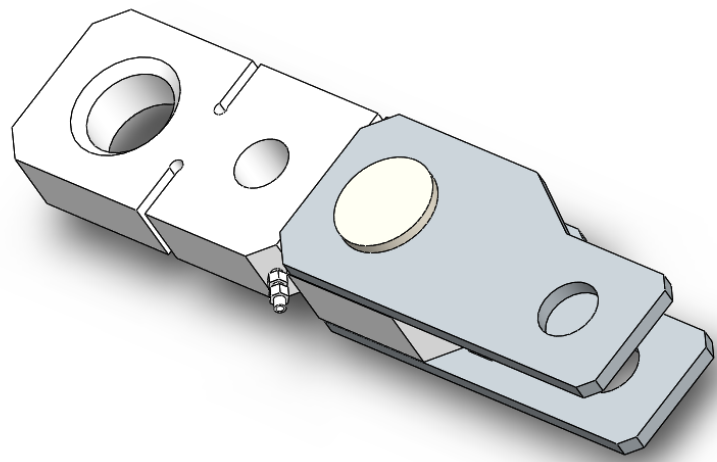

UNLESS OTHERWISE SPECIFIED:
 DIMENSIONS ARE IN MILLIMETERS
 SURFACE FINISH:
 TOLERANCES:
 LINEAR:
 ANGULAR:

FINISH:

DEBURR AND
 BREAK SHARP
 EDGES

DO NOT SCALE DRAWING

REVISION

	NAME	SIGNATURE	DATE
DRAWN			
CHK'D			
APPV'D			
MFG			
Q.A			

Description:

SQB Loadcell 3T

Model: SQB-HT30

SQB-HT100

Part Number:

SQB-LC-HT3

A4

WEIGHT:

SCALE:1:5

SHEET 1 OF 1